

Features

1. 200A ;
Intermittent 200A load.
2. ;
It has two sets of normally open and two sets of normally closed contacts.
3. 24W;
4. 100M (1000VDC) 3.5kV;
5. IP :IP67;
IP protection level: IP67.
6. IEC 60664-1 GB/T14048.1 GB/T14048.4 ;
7. RoHS 2015/863/EU REACH 1907/2006/EC ;

at23
Performance Parameters at23

Contact Arrangement	2K (2NO), 2B (2NC)	
	30m	
	80mV(at 80A)	
	4le, 1s	30ms
	-40 ~85	30ms
	M6	50Hz/60Hz 1500VAC/1min
	3.5g,10~200Hz,1/2	50Hz/60Hz 1500VAC/1min
	5 ~95 RH	100M 1min
	81mm*53mm*75mm	50M 1min
	20000	50g
	3-6N.m	
/	/	

ADC200IJ ADC200IJ Coil Parameters

			Coil Resistance	Coil Power Consumption
12V	70% U _s	5% -40% U _s	6 ± 10%	24W± 10%
24V	70% U _s	5% -40% U _s	24 ± 10%	24W± 10%
36V	70% U _s	5% -40% U _s	54 ± 10%	24W± 10%
48V	70% U _s	5% -40% U _s	96 ± 10%	24W± 10%
60V	70% U _s	5% -40% U _s	150 ± 10%	24W± 10%
72V	70% U _s	5% -40% U _s	216 ± 10%	24W± 10%

Model Coding

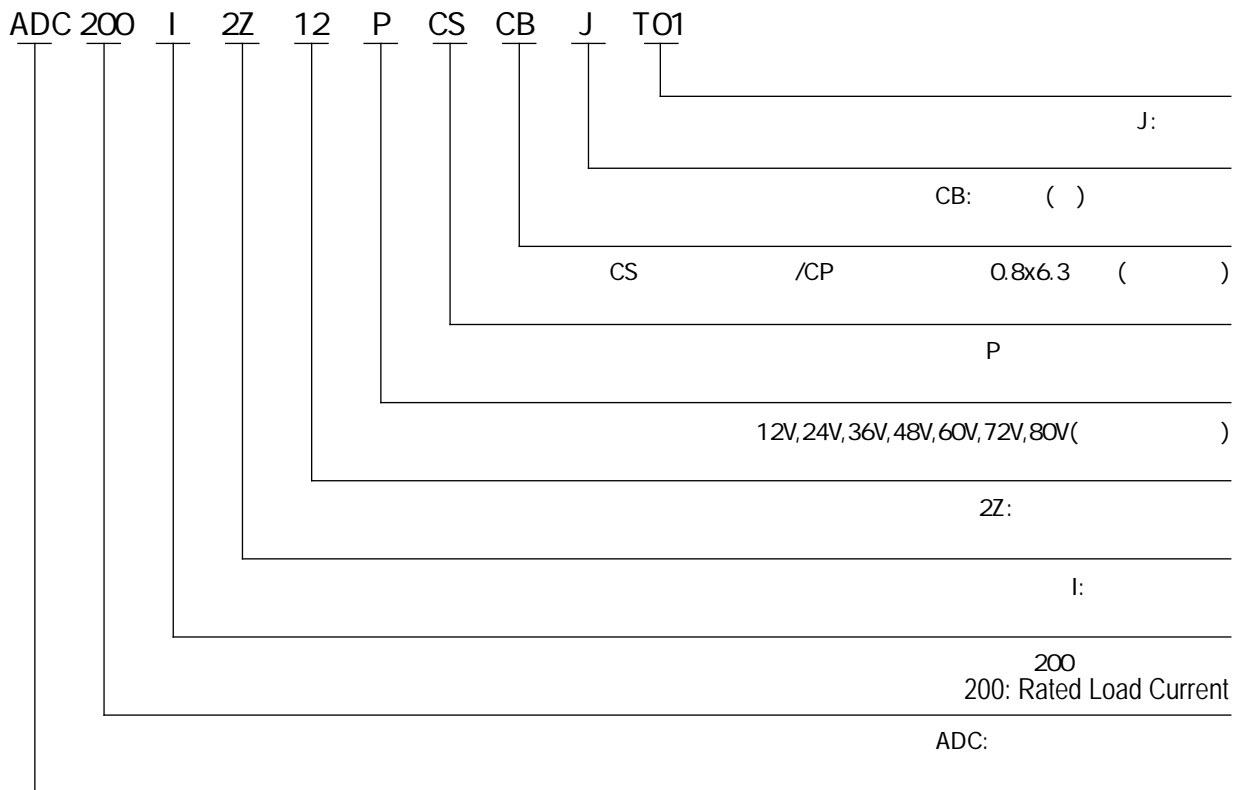

Wiring Diagram

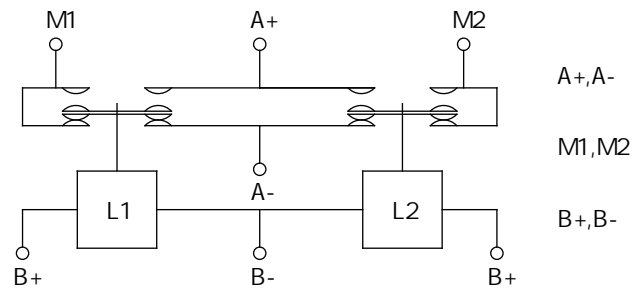

ADC200IJ
ADC200IJ Wiring Diagram

Outline Installation Dimension Drawing

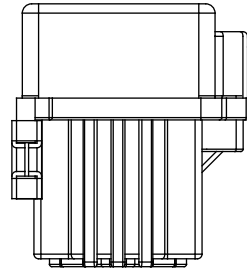
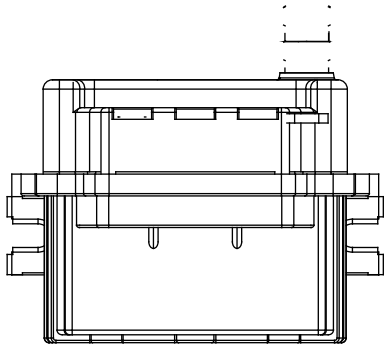

4-M6
Load Wiring 4-M6
3.0-6.0N.m

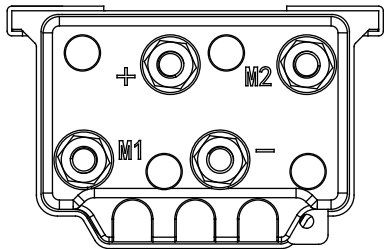

3-M3
0.5-0.8N.m

4-M6
3.0-6.0N.m

3-0.8x6.3
Spade Terminal

Usage Cautions

1.

2.